

Инжекторы серии DL-32

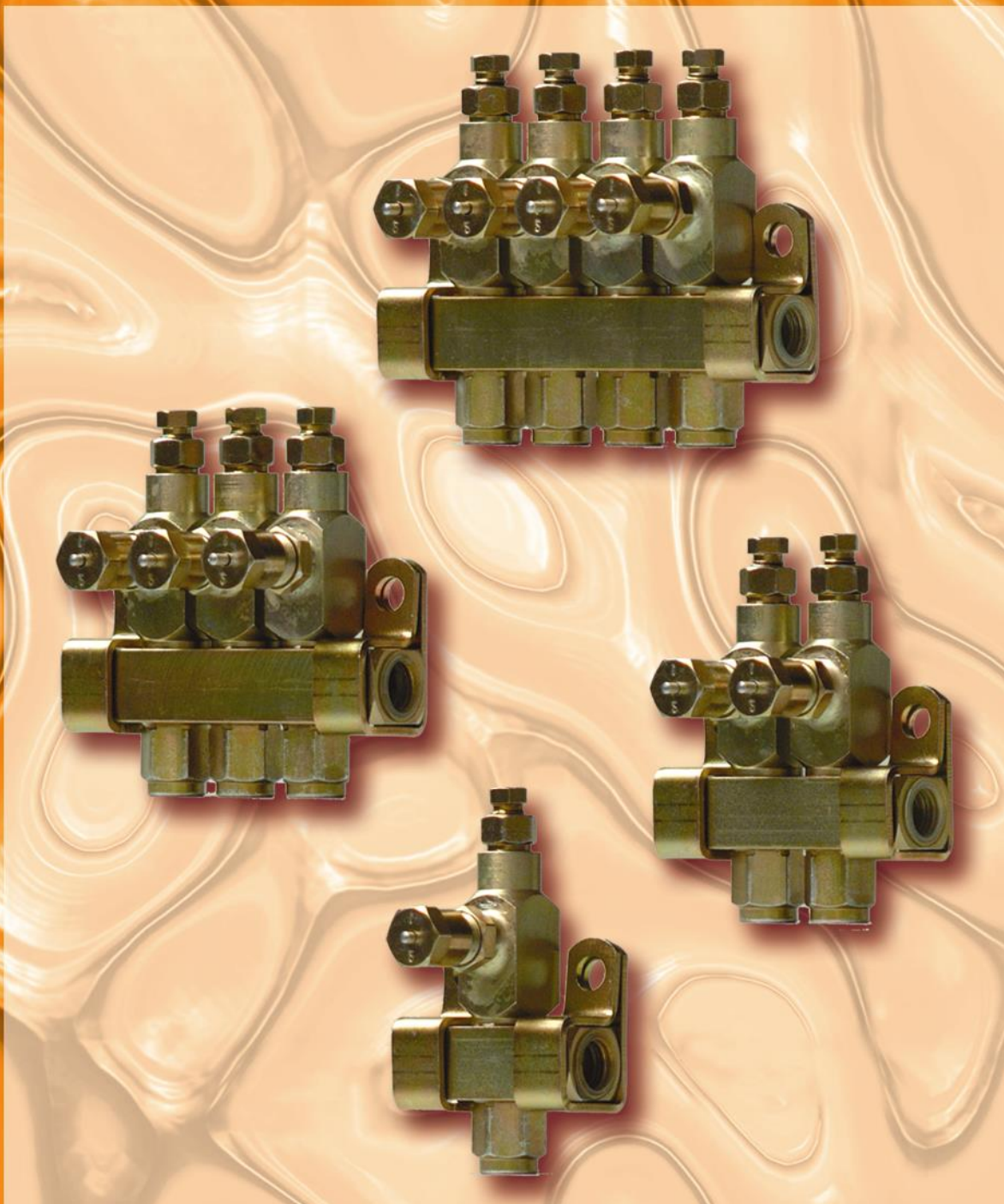

Инжекторы DL - 32

Инжекторы серии DL - 32

DL-32



| | | | | | | | |
|-----------------------|--------|--------------------------------------|-------------------------------------|------------------|-------------------|-------------------|-----------------|
| 220 cSt (1018 SUS) | NLGI 2 | 0,02 ³ (0,0012 cu.in.) | 0,13 ³ (0,008 cu.in.) | 83 (1220 psi) | 240 (3528 psi) | 103 (1514 psi) | 13 (205 psi) |
|-----------------------|--------|--------------------------------------|-------------------------------------|------------------|-------------------|-------------------|-----------------|

0,026³ (0,0016 cu.in)

.5

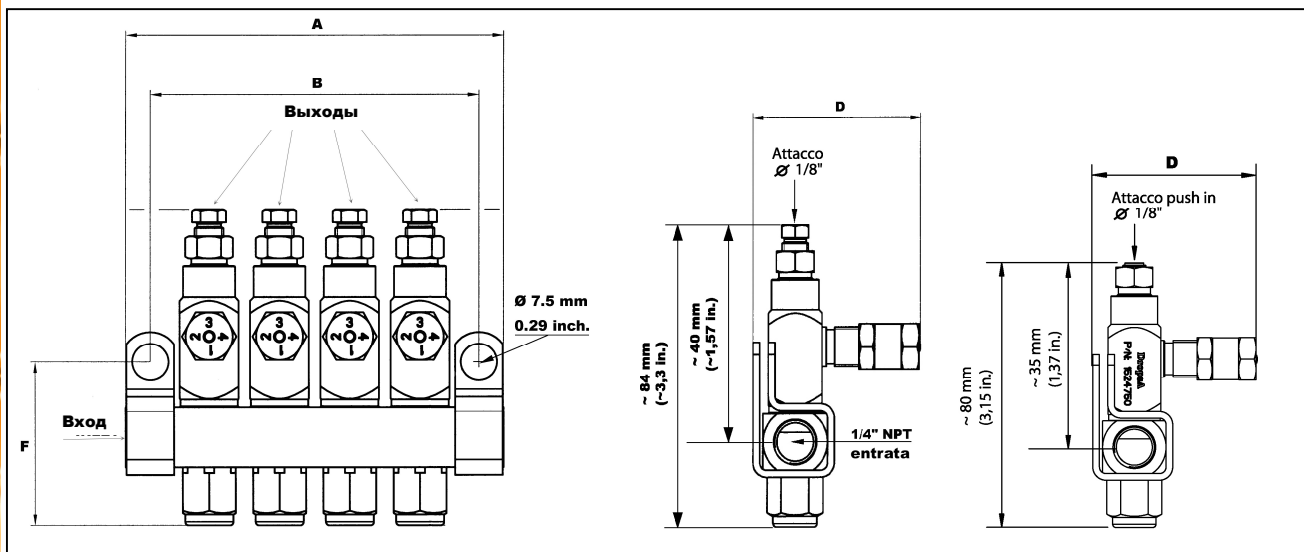

| () | () Push-in 1/8" | () inox AISI 304) | | , (inch) | | | |
|---------|---------------------|--------------------------|---|----------------|----------------|----------------|----------------|
| | | | | A | B | D | F |
| 1524521 | 1524751 | 1524921 | 1 | 44,5 (1,75) | 31,7 (1,25) | ~50 (~1,96) | ~44 (~1,73) |
| 1524522 | 1524752 | 1524922 | 2 | 63,5 (2,5) | 50,7 (2) | | |
| 1524523 | 1524753 | 1524923 | 3 | 82,5 (3,24) | 69,7 (2,74) | | |
| 1524524 | 1524754 | 1524924 | 4 | 101,5 (4) | 88,7 (3,5) | | |

| | |
|----------------|---------|
| | |
| , 1/8+ | 1524520 |
| , push-in 1/8+ | 1524750 |
| Inox, 1/8+ | 1524920 |

1. Ø 1/8+
2. NBR (max. 90°C - 194°F).
3. , Ø 1/4+20 UNC

ИТАЛИЯ
Dropsa SpA
t. +39 02-250791
f. +39 02-25079767

ВЕЛИКОБРИТАНИЯ
Dropsa (UK) Ltd
t. +44 (0)1784-431177
f. +44 (0)1784-438598

ГЕРМАНИЯ
Dropsa GmbH
t. +49 (0)211-394-011
f. +49 (0)211-394-013

РОССИЯ
Dropsa OOO
t. +7(473)2021000

КИТАЙ
Dropsa Lubrication Systems
(Shanghai) Co., Ltd
t. +86 (021) 67740275
f. +86 (021) 67740205

С.Ш.А.
Dropsa USA Incorporated
t. +1 586-566-1540
f. +1 586-566-1541

АВСТРАЛИЯ
Dropsa Australia Pty
t. +61 (02)-9938-6644
f. +61 (0)2-9938-6611

БРАЗИЛИЯ
Dropsa Do Brasil Ind.e.Com.Ltda
t. +55 (0)11-563-10007
f. +55 (0)11-563-19408

Web site:
<http://www.dropsa.com>

E-mail:
sales@dropsa.com

WK 27/15
C2070PI